



Practical Training Radioastronomy



Hardware Overview

Ing. Harald Chmela, BSc, MSc

harald.chmela@univie.ac.at

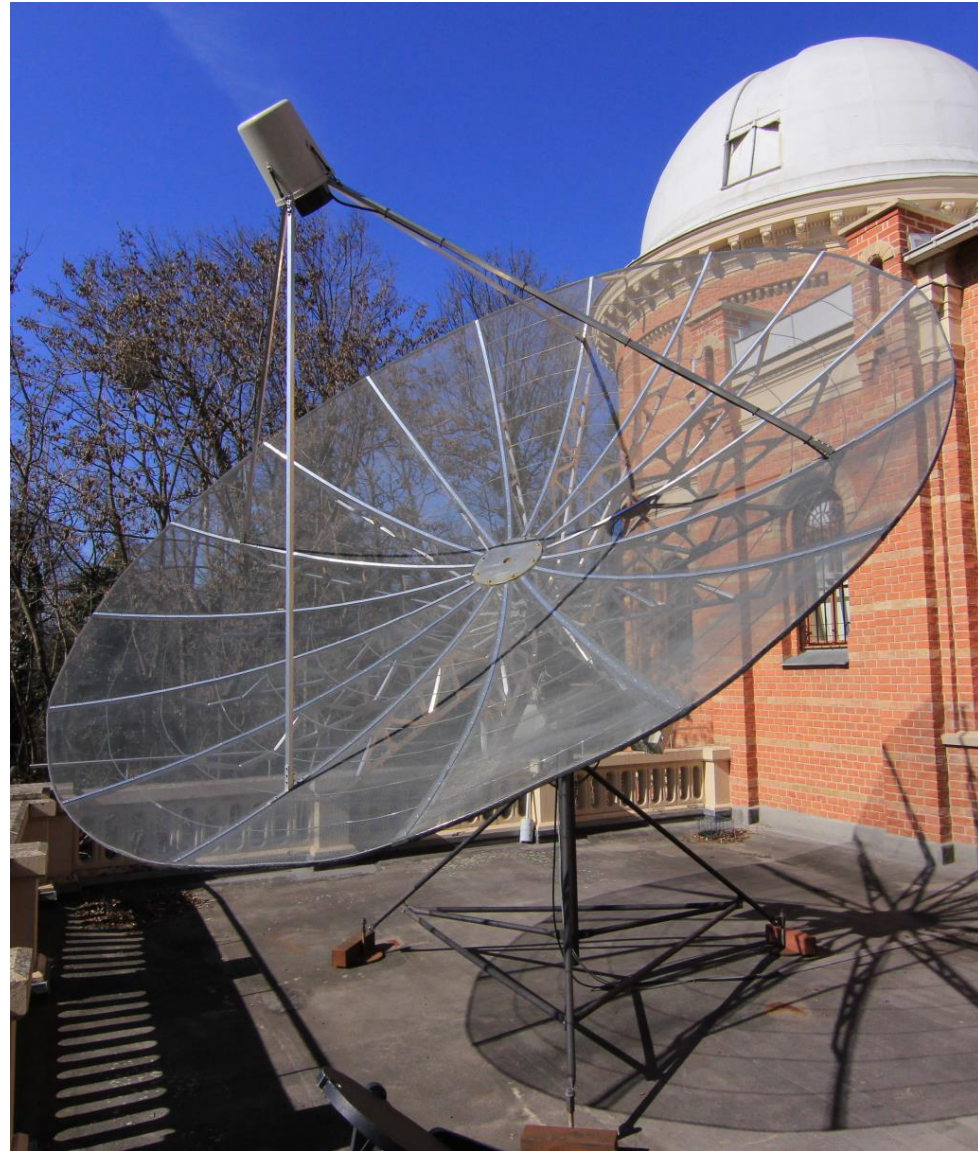

Image credits: ALMA (ESO/NAOJ/NRAO), C. Malin & J. Guarda

V2.8 3.1.2026

New Radio Telescope Fact Sheet

Diameter: 4,5 m
Beam width: 3,2°@1420 MHz
2,9°@1612 MHz
Antenna gain: 33 dBi
Frequency: 1415...1425 MHz
1607...1617 MHz
Sensitivity: ~100Jy



NRT First Light 5.9.2023

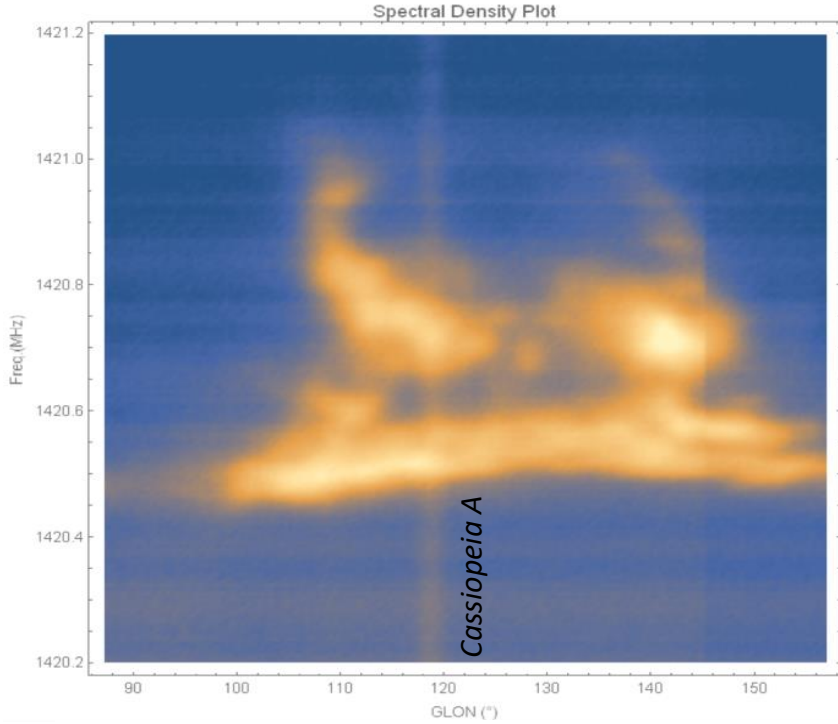

Transitpath through the galactic plane

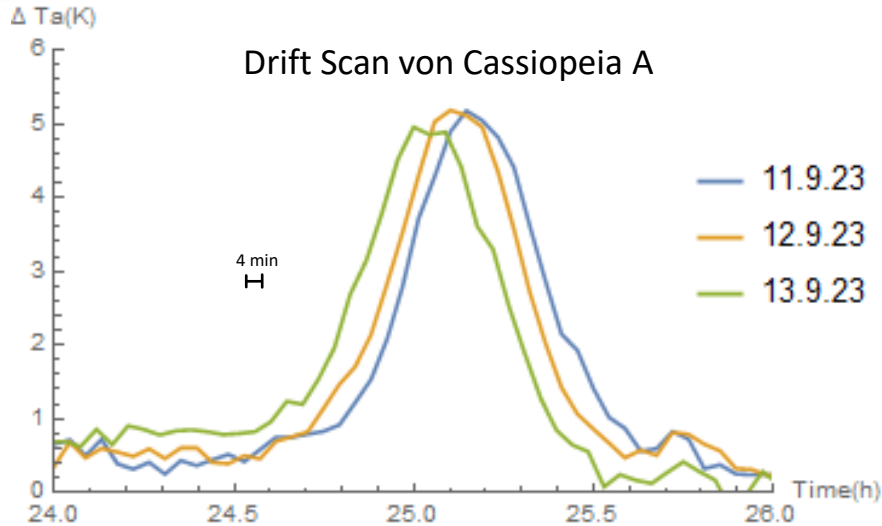
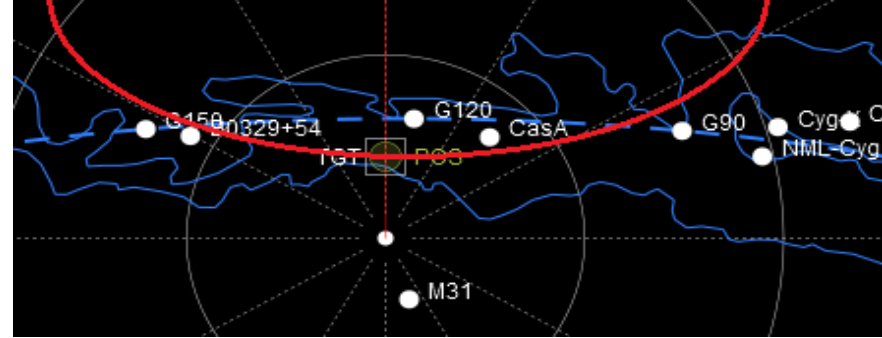

Altazimuth Mount Drive

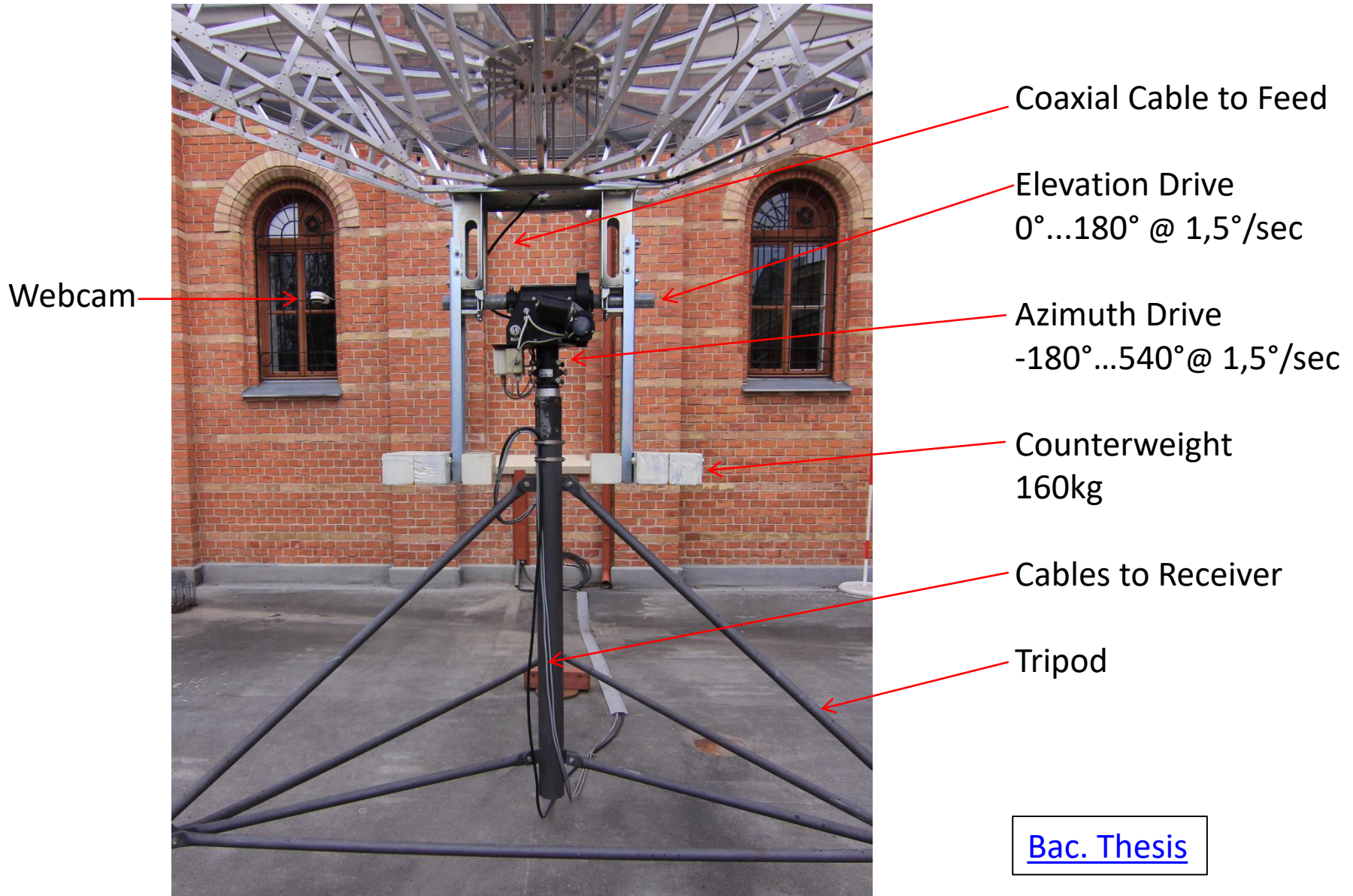

Antenna Basics

Theoretical antenna diagram for a 2.3 meter dish @ 1420 MHz

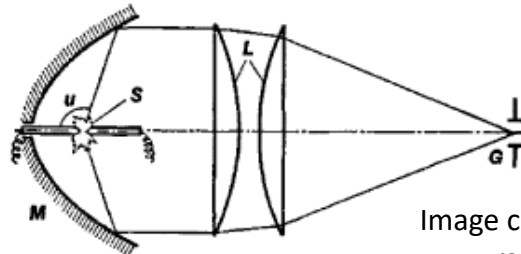
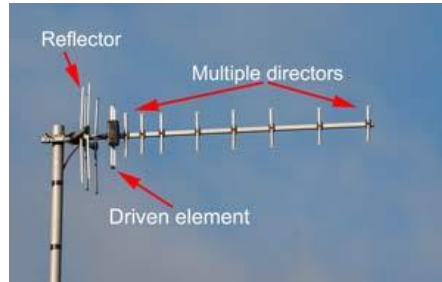
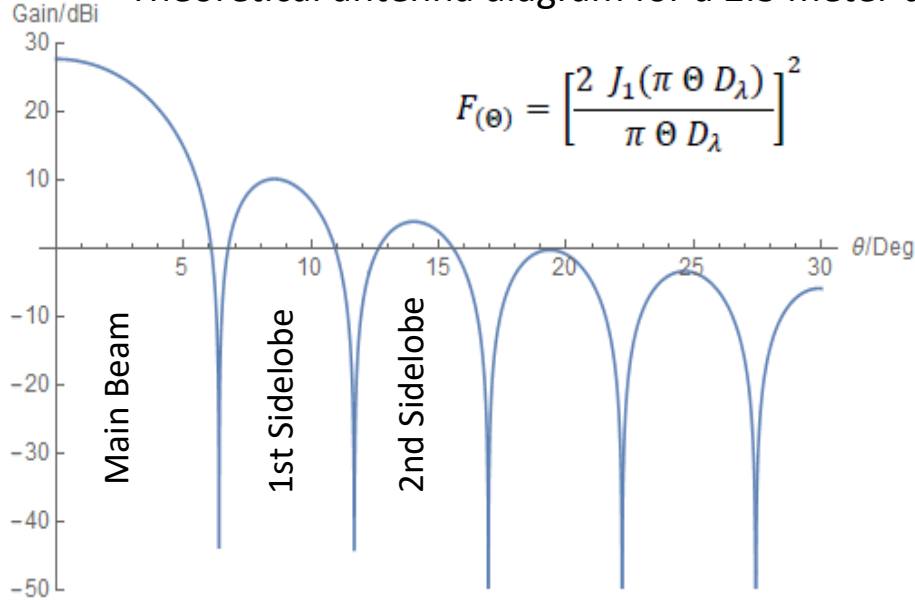

Austria's highest antenna, 265m destroyed 02/2010

Image credit: www.eso.org/public/teles-instr/alma/antennas/

Image credit:
www.radio-electronics.com/info/antennas/yagi
encyclopedia2.thefreedictionary.com/Condenser

SRT Primary Focus Assembly

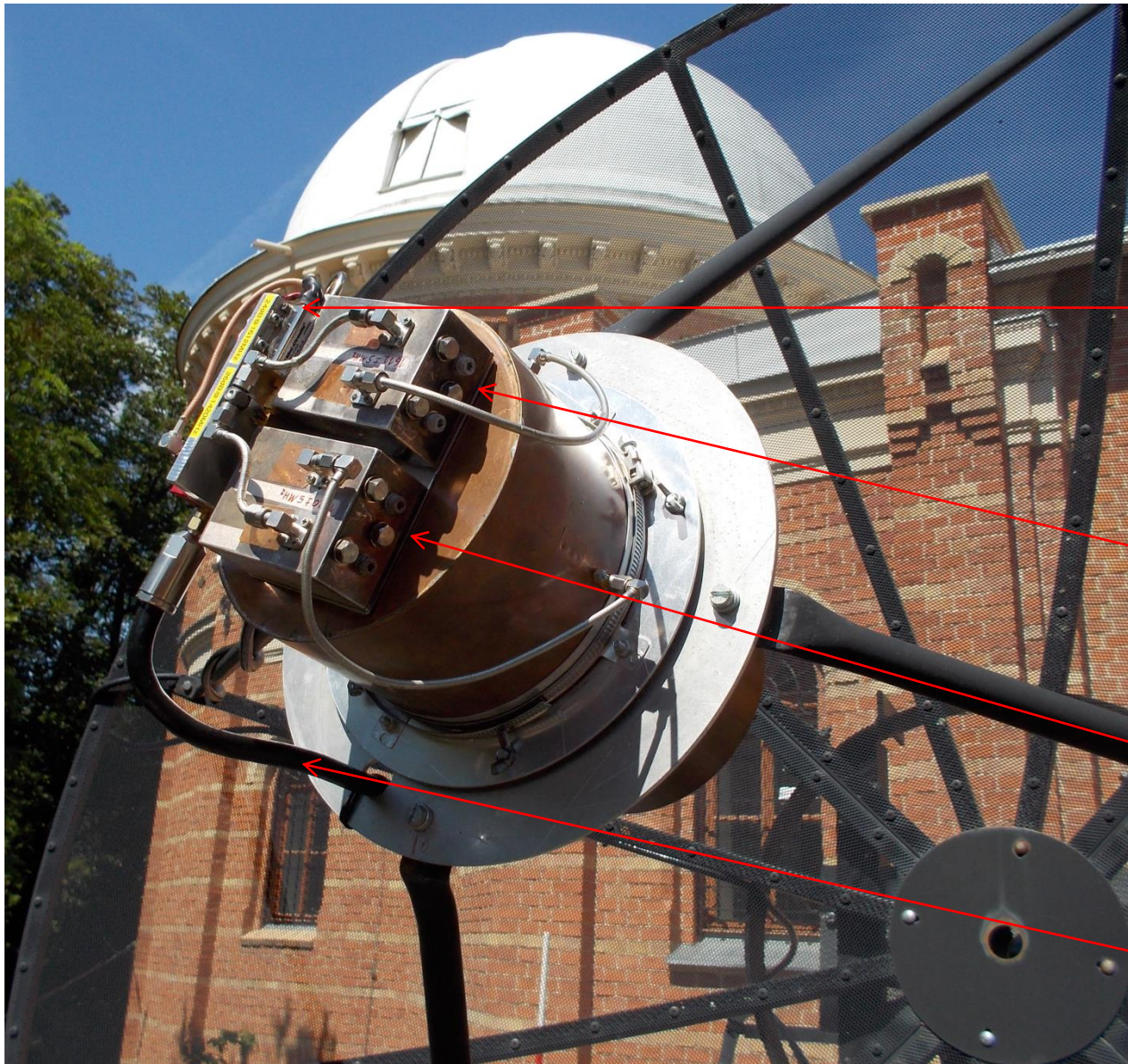

2x Amplifier
26dB@1420MHz
24dB@1612MHz

Band Filter
1612MHz

Band Filter
1420MHz

Coaxial Cable
to Receiver

Can Antenna used as Feed

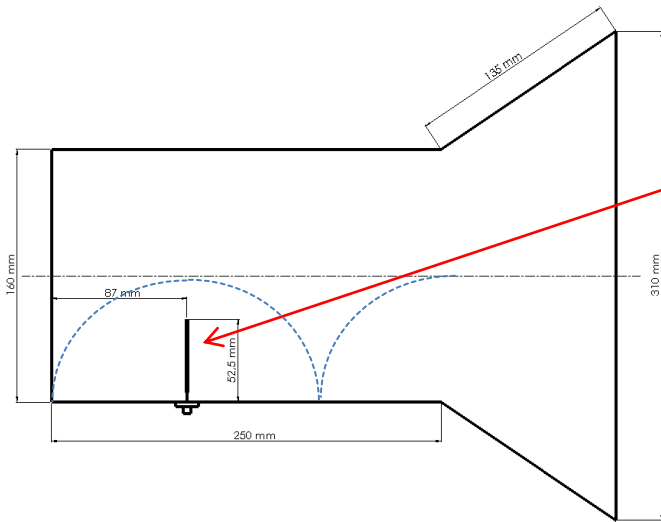

$\lambda/4$ Antenna
@1420MHz

$\lambda/4$ Antenna
@1612MHz

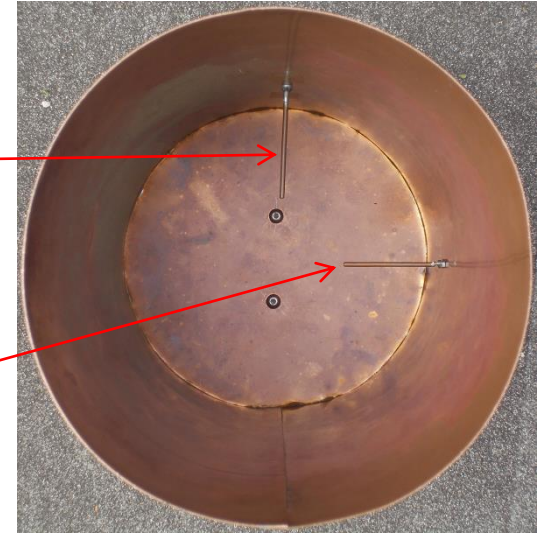

Antenna Diagram
@1420MHz

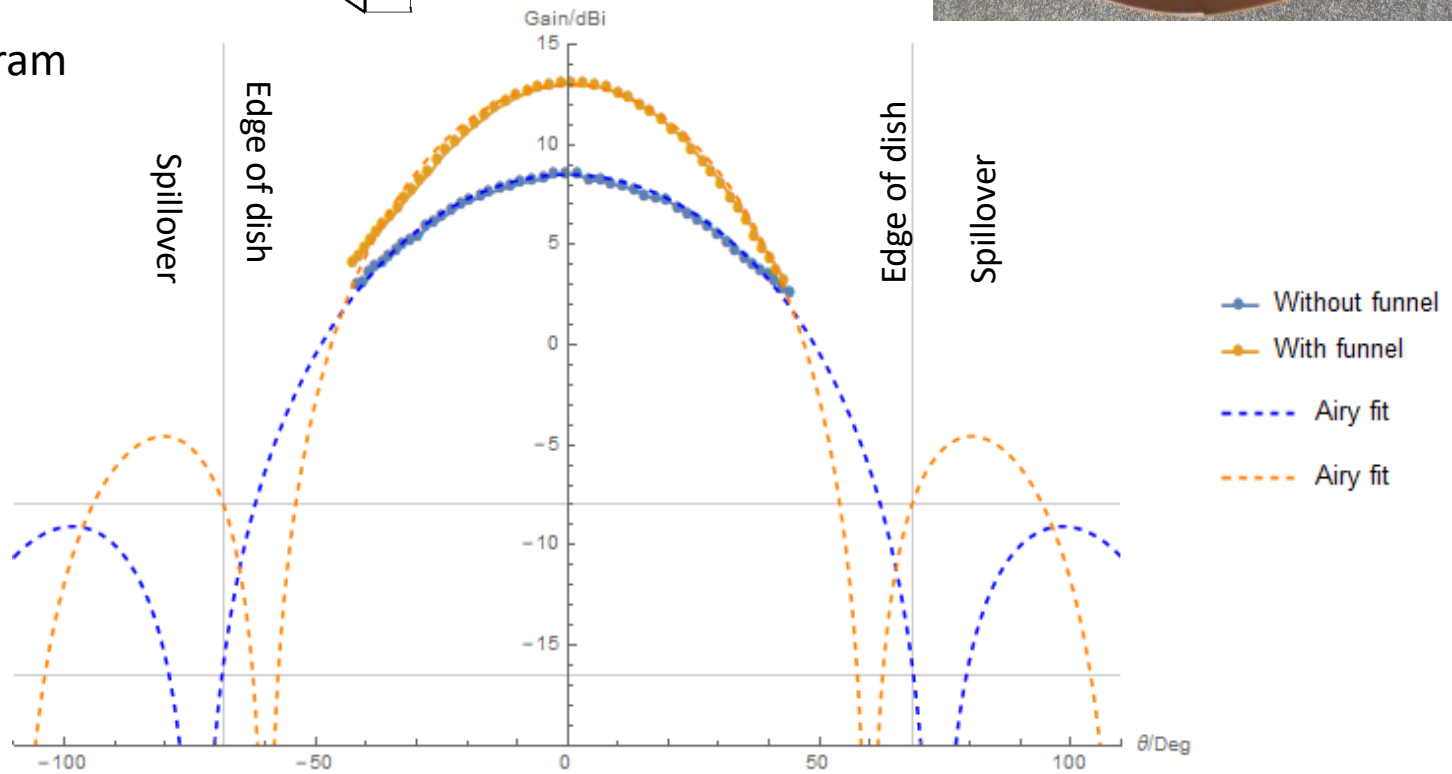

Two Cavity Bandpass Filter

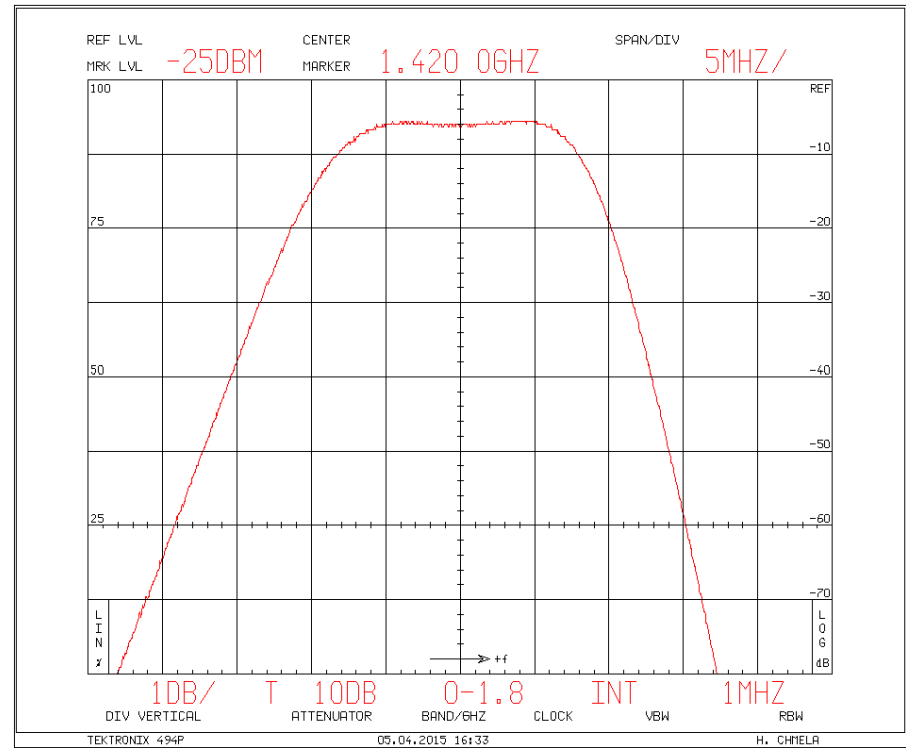
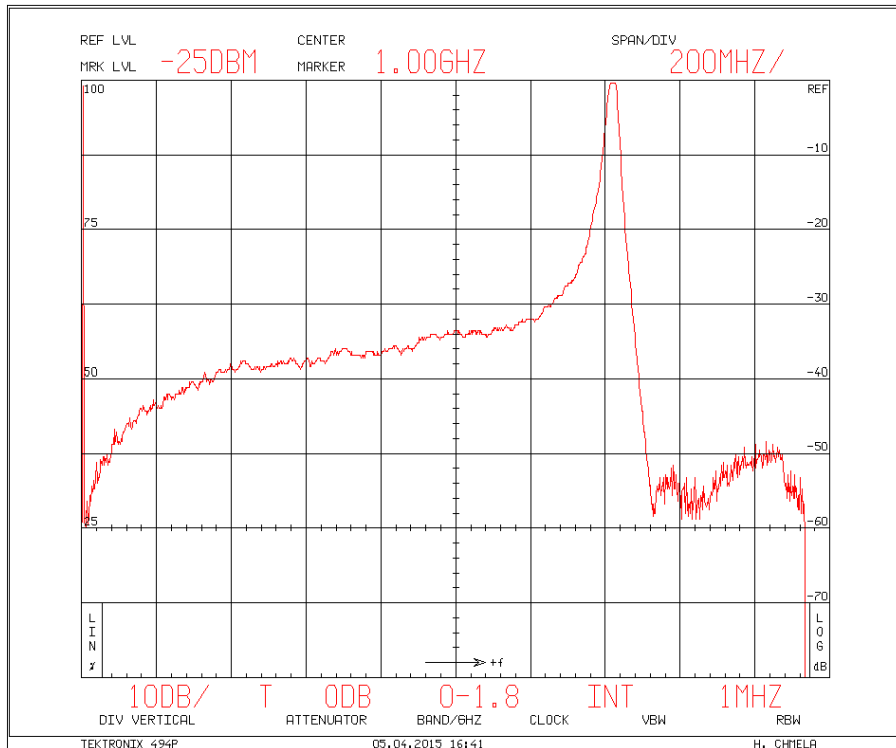
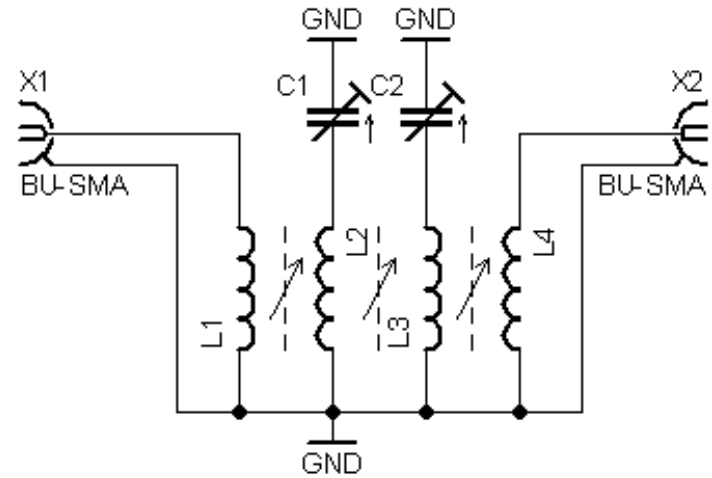
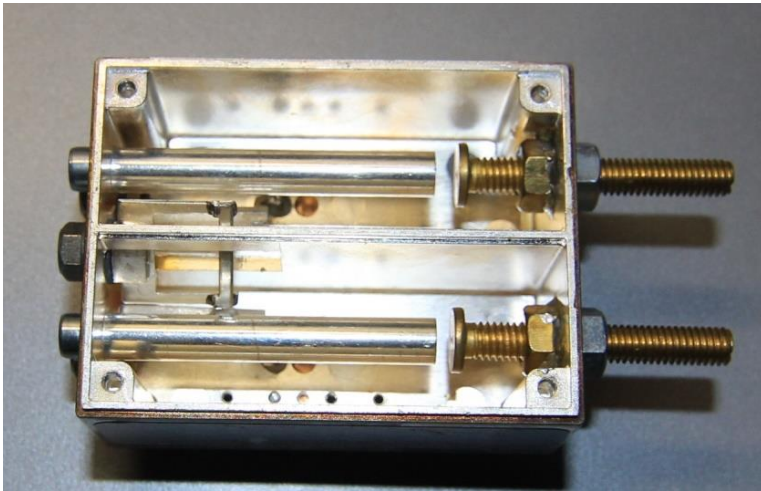

Front End Amplifier

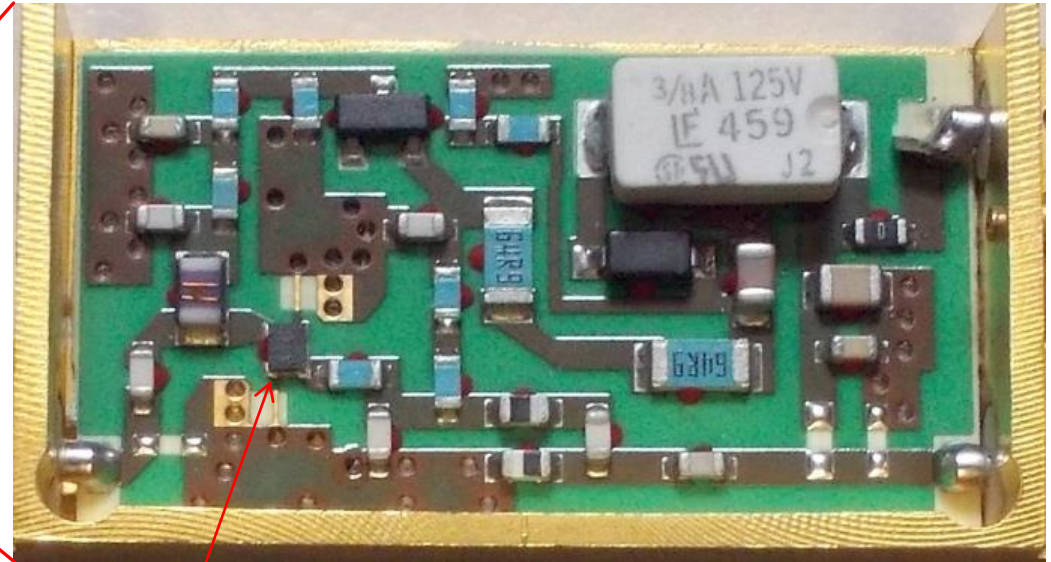

Type: [ZX60-1614 LN-S](#)

To Receiver

Bias Tee

The one and only pixel of the telescope

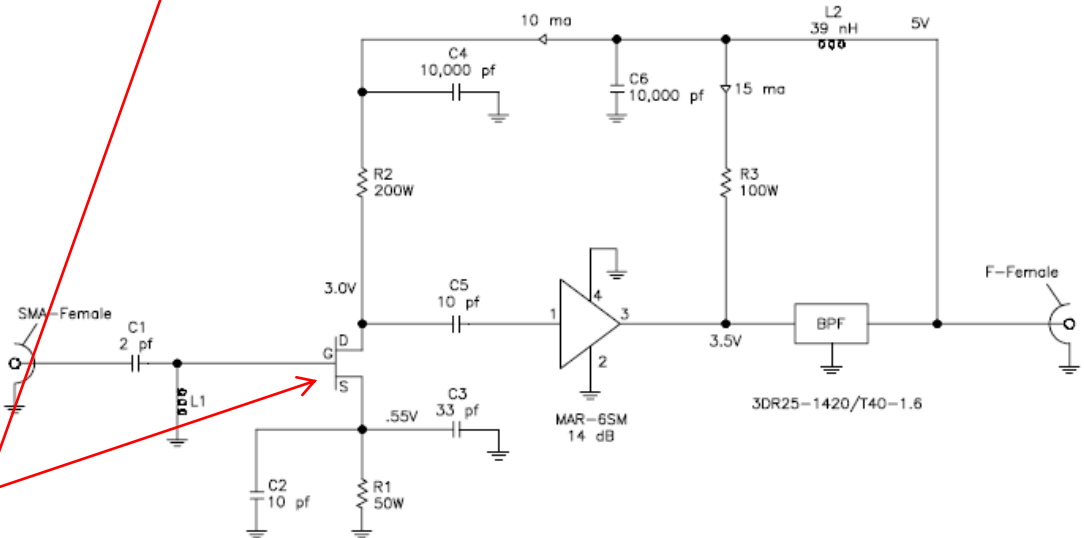

Superheterodyne Receiver

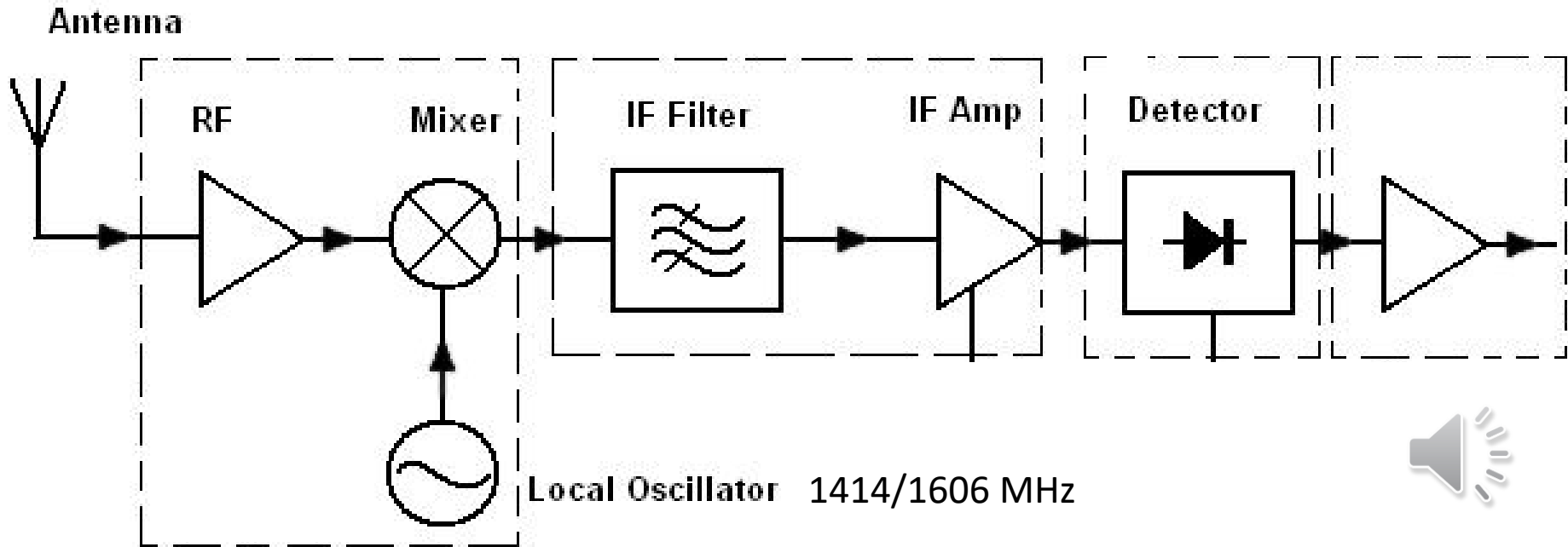

RF:
1420/1612 MHz
Amplification
Tuning
Down conversion

IF:
6 MHz
11MHz Bandwidth

IF Detection
Samplingrate 66,67MHz
FFT Bandwidth 190kHz

Mixer Simulation 1

[Mixer simulation 1 in Mathematica](#)

Linear Superposition

Nonlinear Superposition

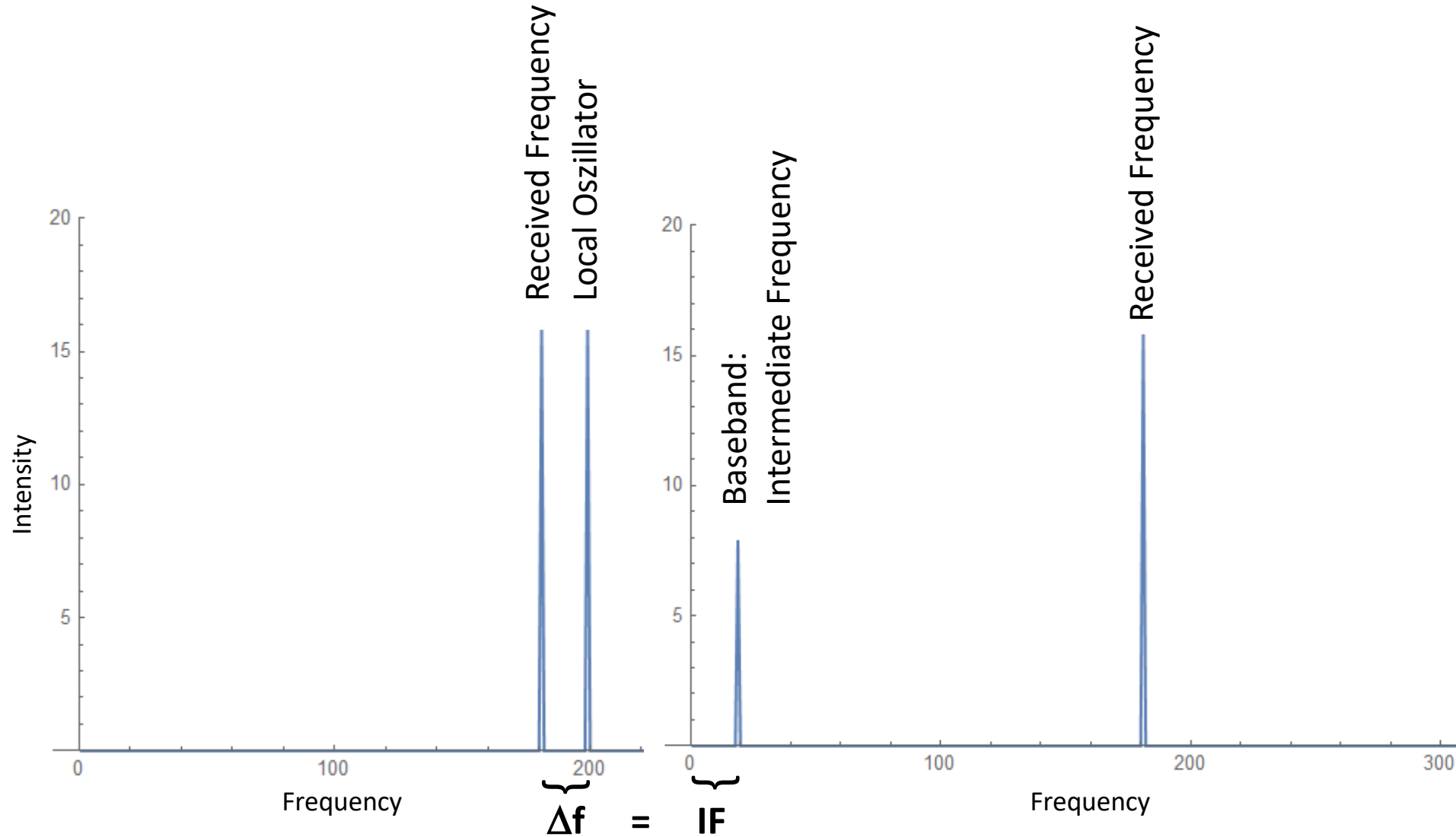

Mixer Simulation 2

[Mixer simulation 2 in Mathematica](#)

Nonlinear distortion in time domain

leads to unwanted mixing in frequency domain

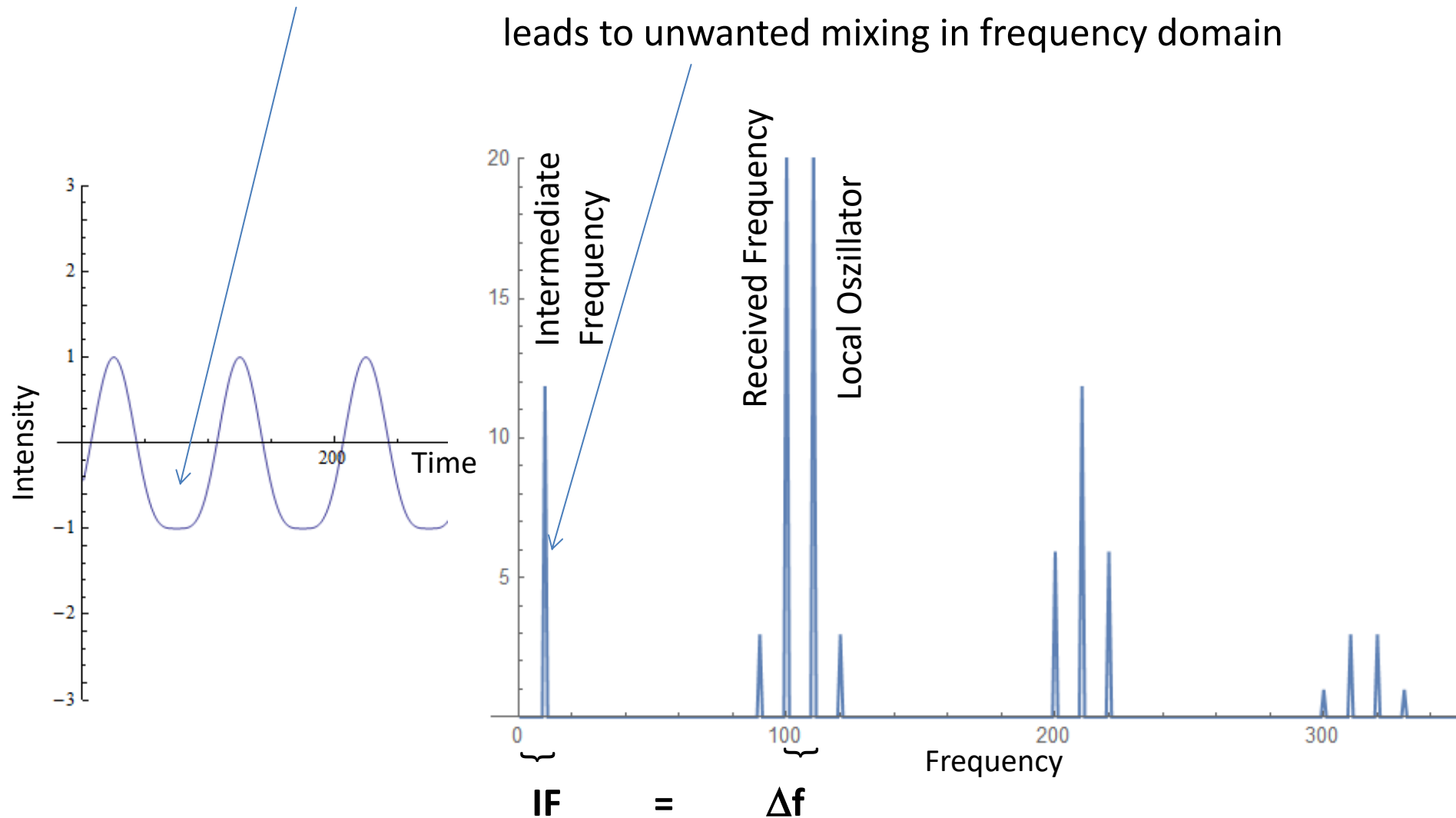

Image Rejection Receiver

Detector Radio Receiver 1924



Image credit:
www.radiomuseum.ch/13804_detektorempfaenger_c1_c_1.html

NRT Receiver 2024

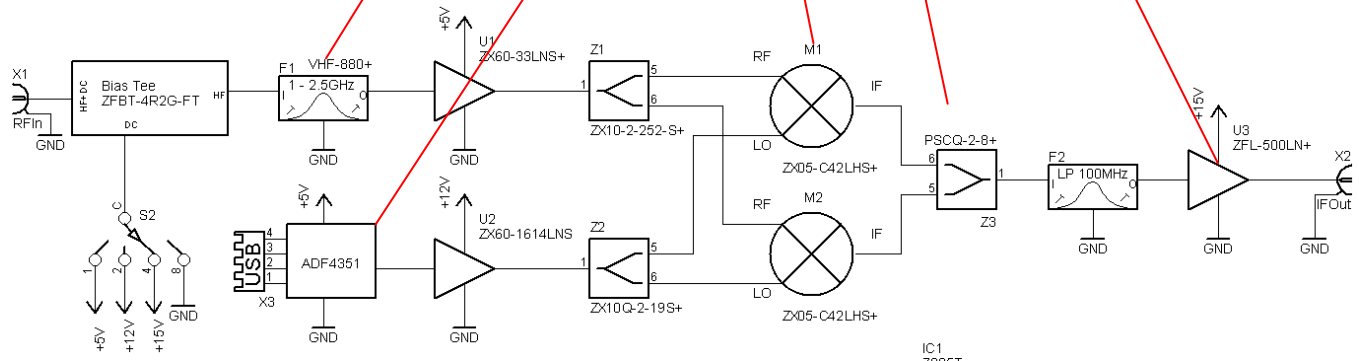
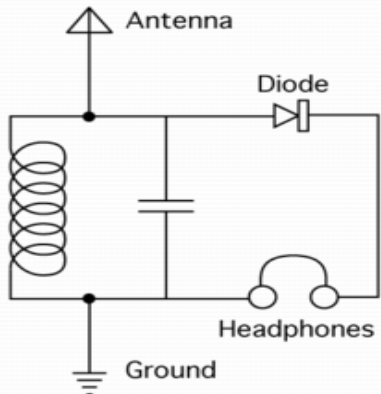
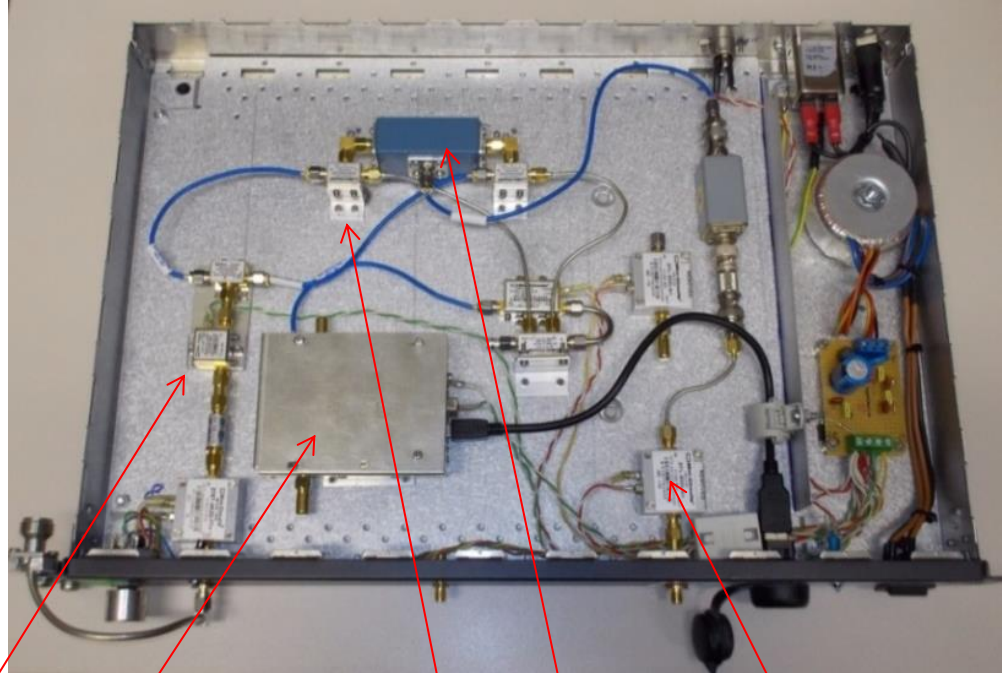

Local Oscillator Synthesizer

Image Rejection Mixer

ZF-Output 6 MHz

Detection System / Spectrometer

- SDR14 – Software Defined Radio
- 14 Bit ADC, Digital Downconverter
Signal/Noise Conversion Gain
- Numerical Tuning, NCO
- Complex IQ-Sample Output
- FFT on external Computer



Image Credit: www.universal-radio.com

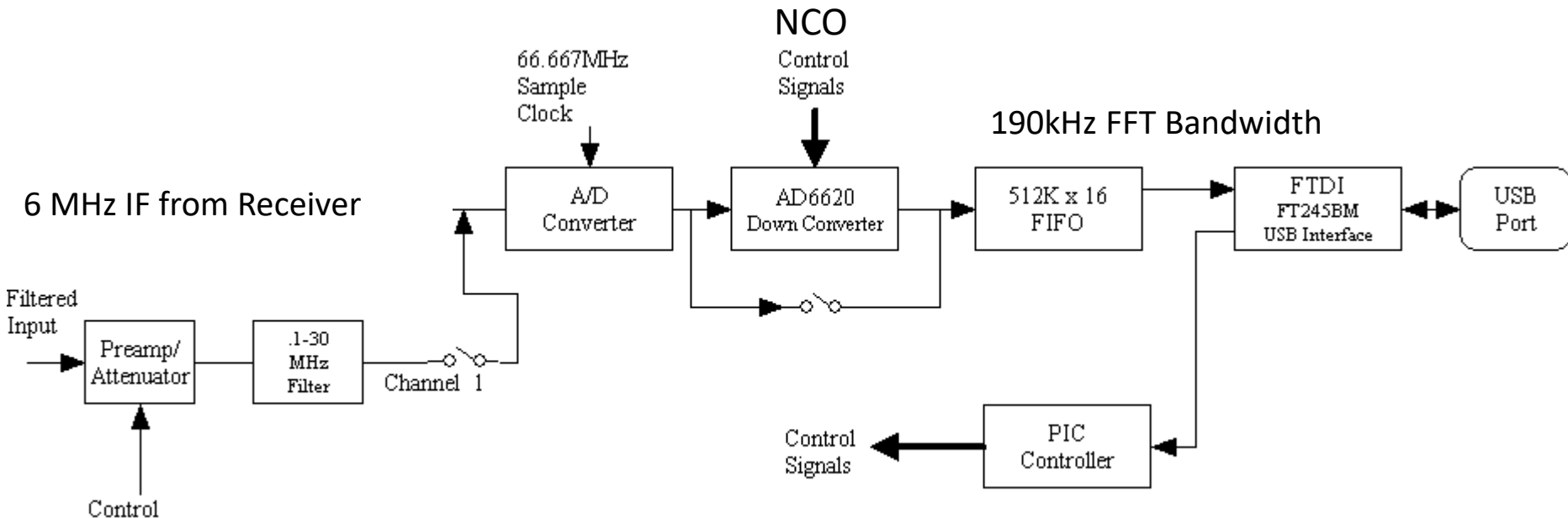

Block Diagram, Image Credit: www.moetronix.com/sdr14info.htm

ALMA's Band 3 Receiver

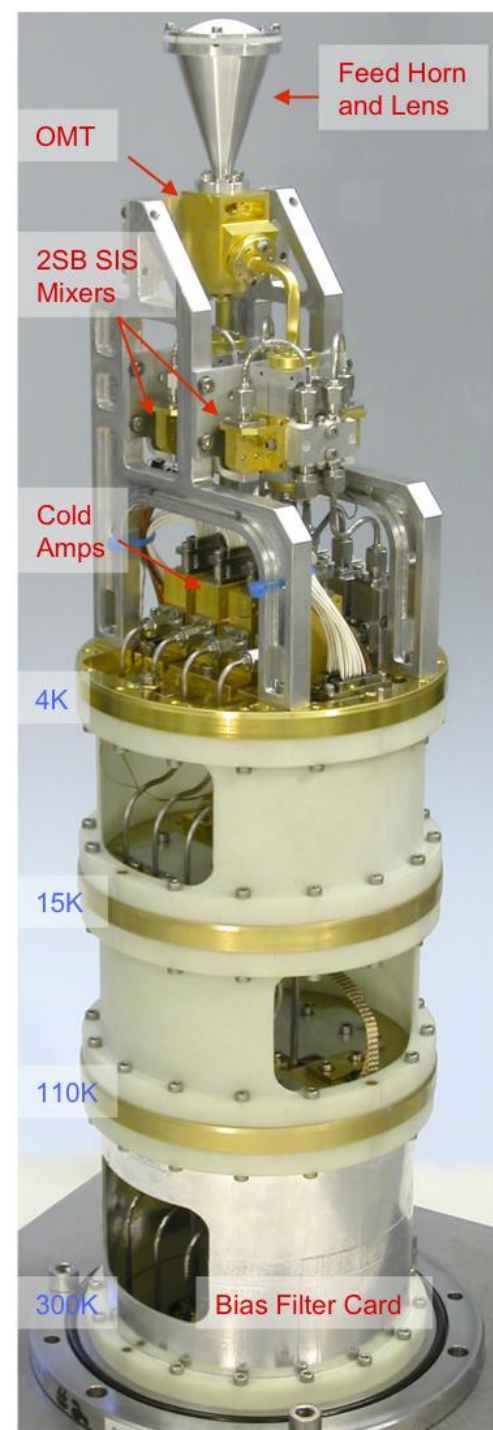
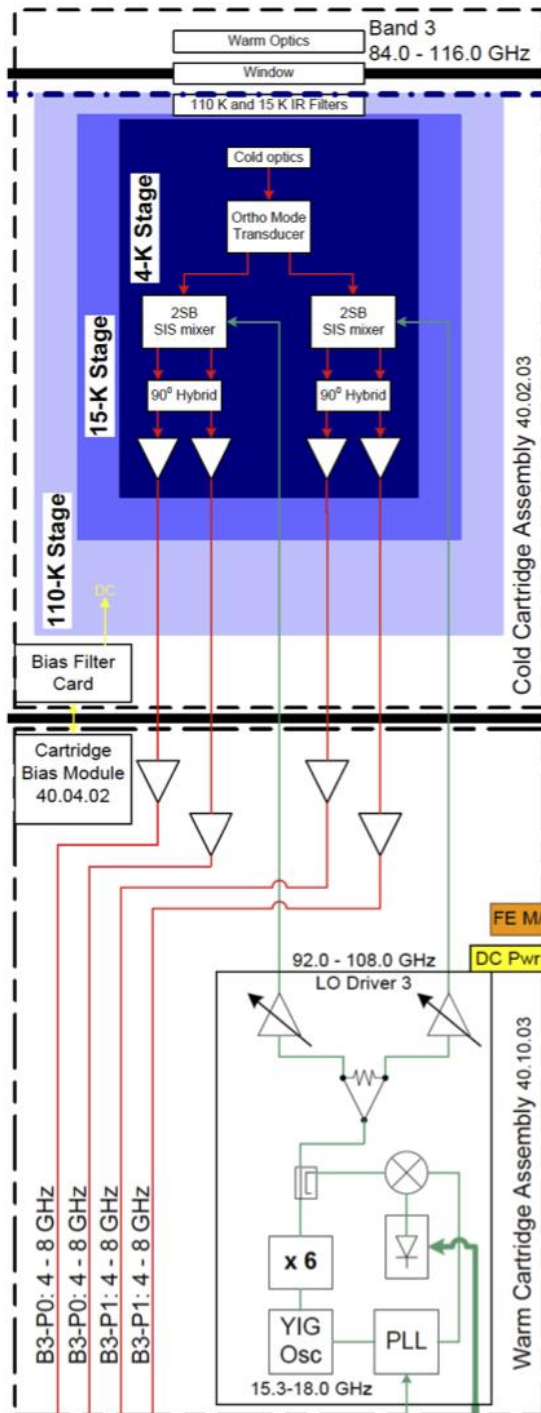
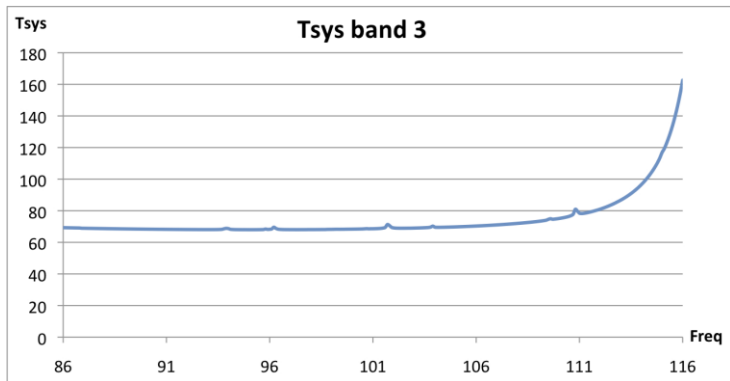

Image credits:
ALMA Cycle 2 Technical Handbook V.1.1
www.almascience.eso.org